

Montageanleitung zum Beschlag "DISPENSA-SWING"

Art.-Nr.: 014430

Assembly instructions for DISPENSA-SWING fitting

Order no: 014430

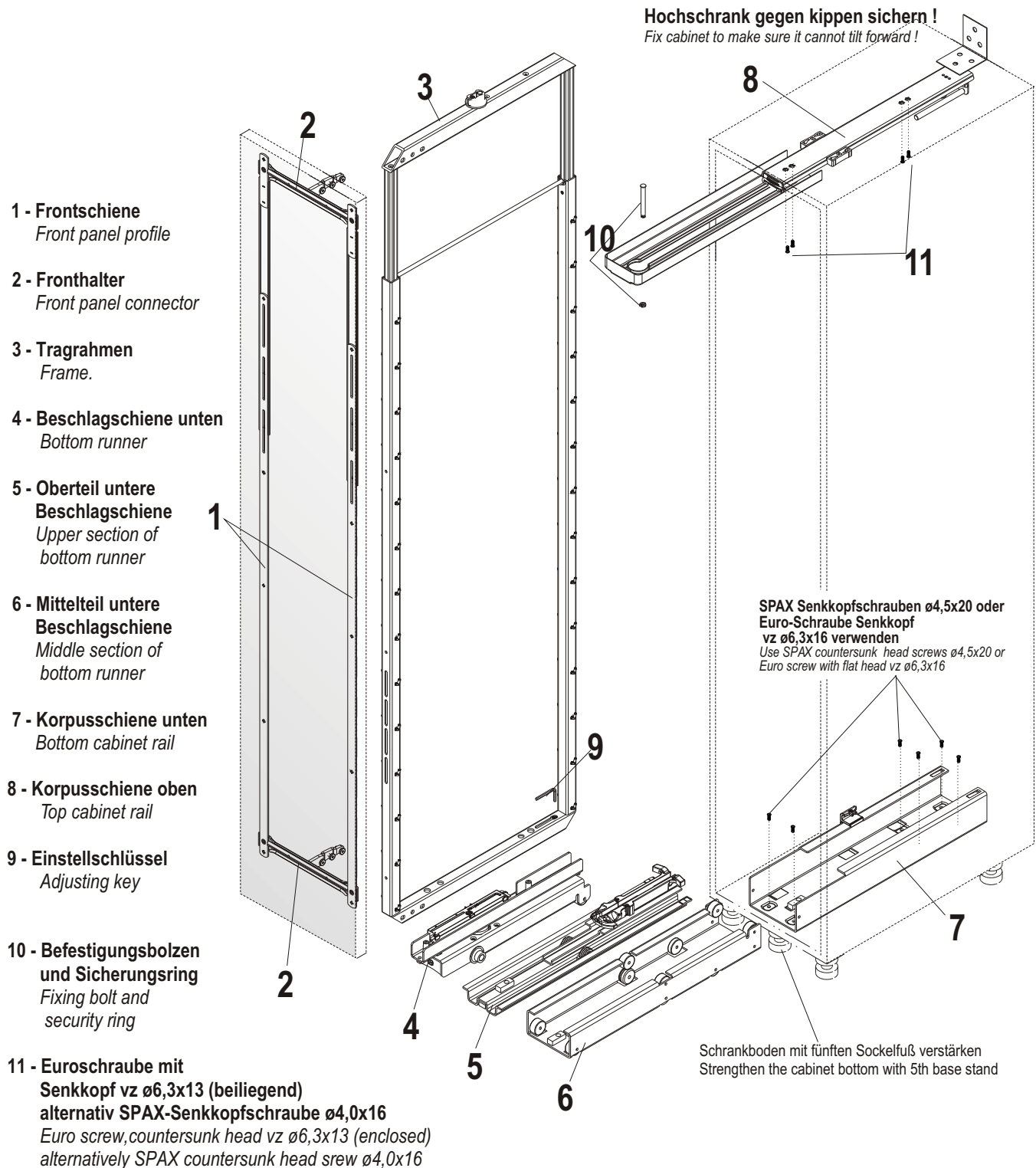

A. Tragrahmenhöhe einstellen (3)
Adjust frame height (3)

lichte Schrankhöhe B - 124 = Rahmen-Aussenmaß A
Inside cabinet height B - 124 = Outer frame height A

$$B = \dots\dots\dots\text{mm} - 124 = A = \dots\dots\dots\text{mm}$$

B. Montage obere Korpusschiene (10)
Montage untere Korpusschiene (9)
Attach top cabinet rail (10)
Attach bottom cabinet rail (9)

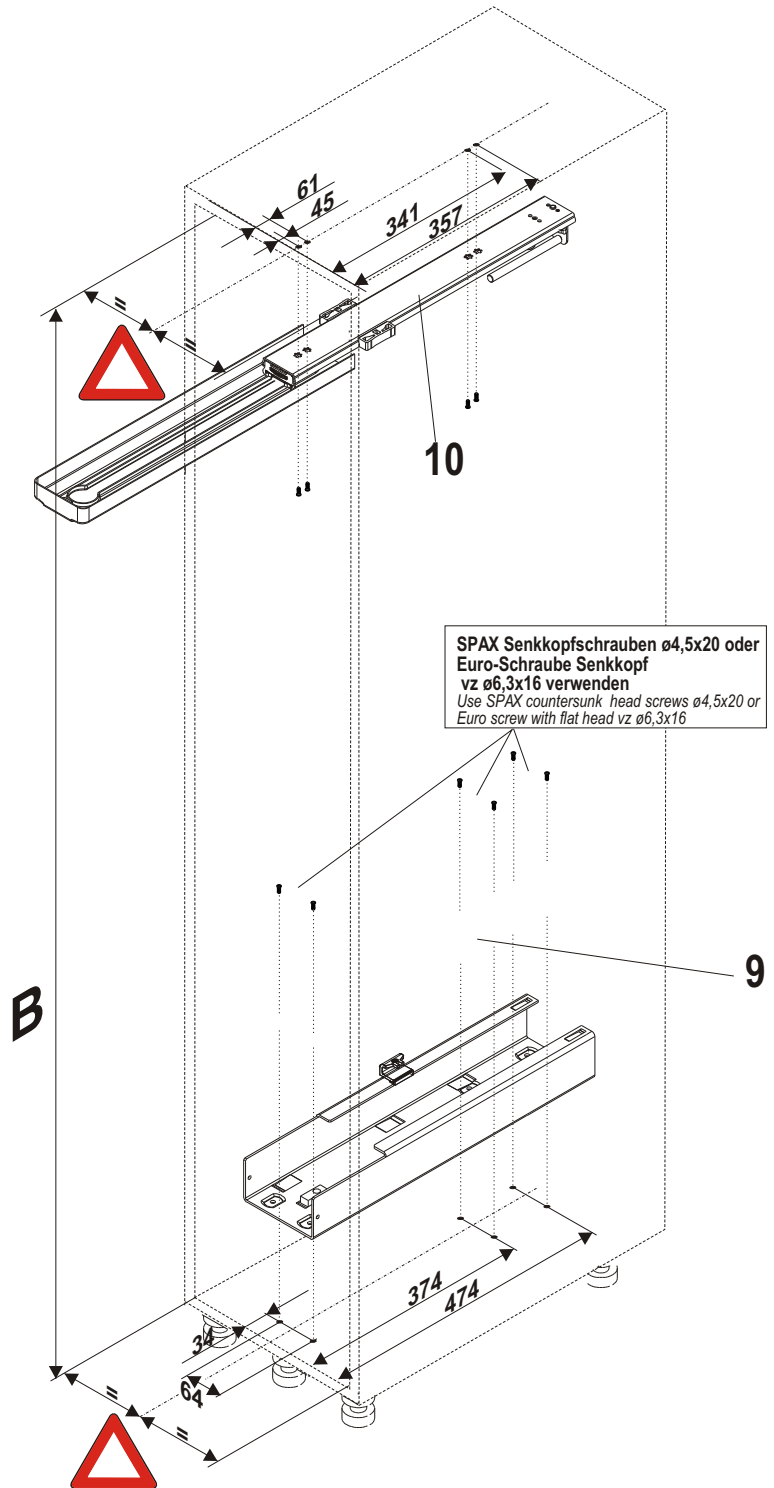
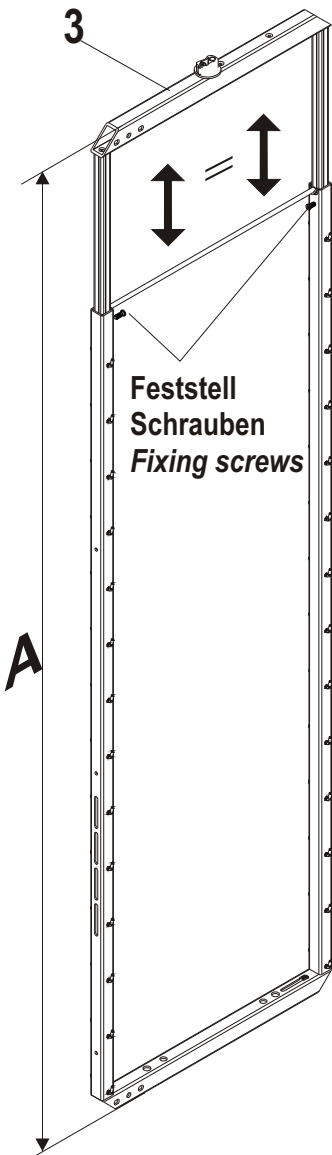

C. Montage untere Beschlagschiene (6).

Das Ende des Langloches muß am Gewinde anliegen !

Attach bottom cabinet runner (6)

The end of the oblong hole must line up with the thread !

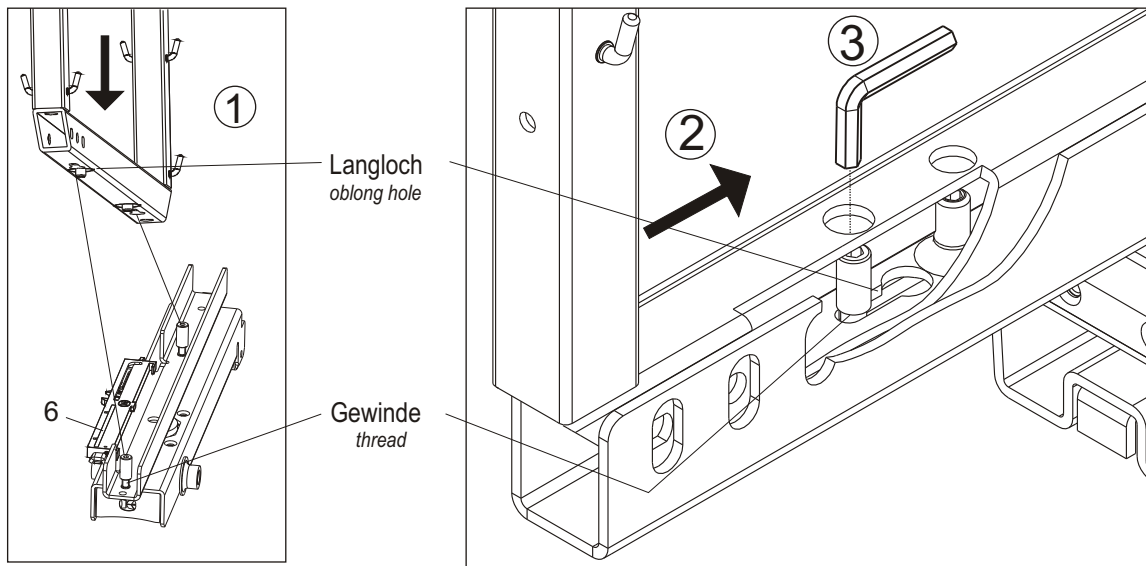

D. Montage untere Beschlagschiene (6,7,8)

Attach bottom cabinet runner sections (6,7,8)

Vor dem Zusammenbau,
unteren Auszug ausputzen.
Bohrspäne und Schmutz entfernen
*please clean the bottom runner in advance
to the mounting of the complete pull-out*

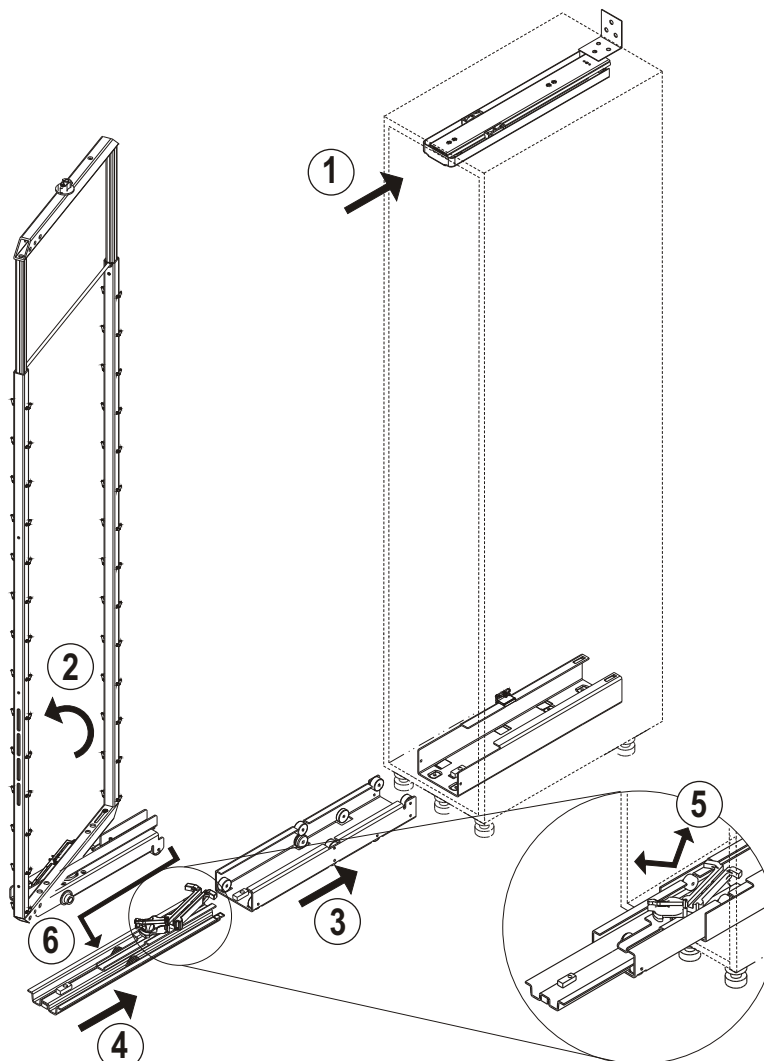

E. MontageTragrahmen (3) an obere Korpuschiene (10). Attach frame (3) to top cabinet rail (10)

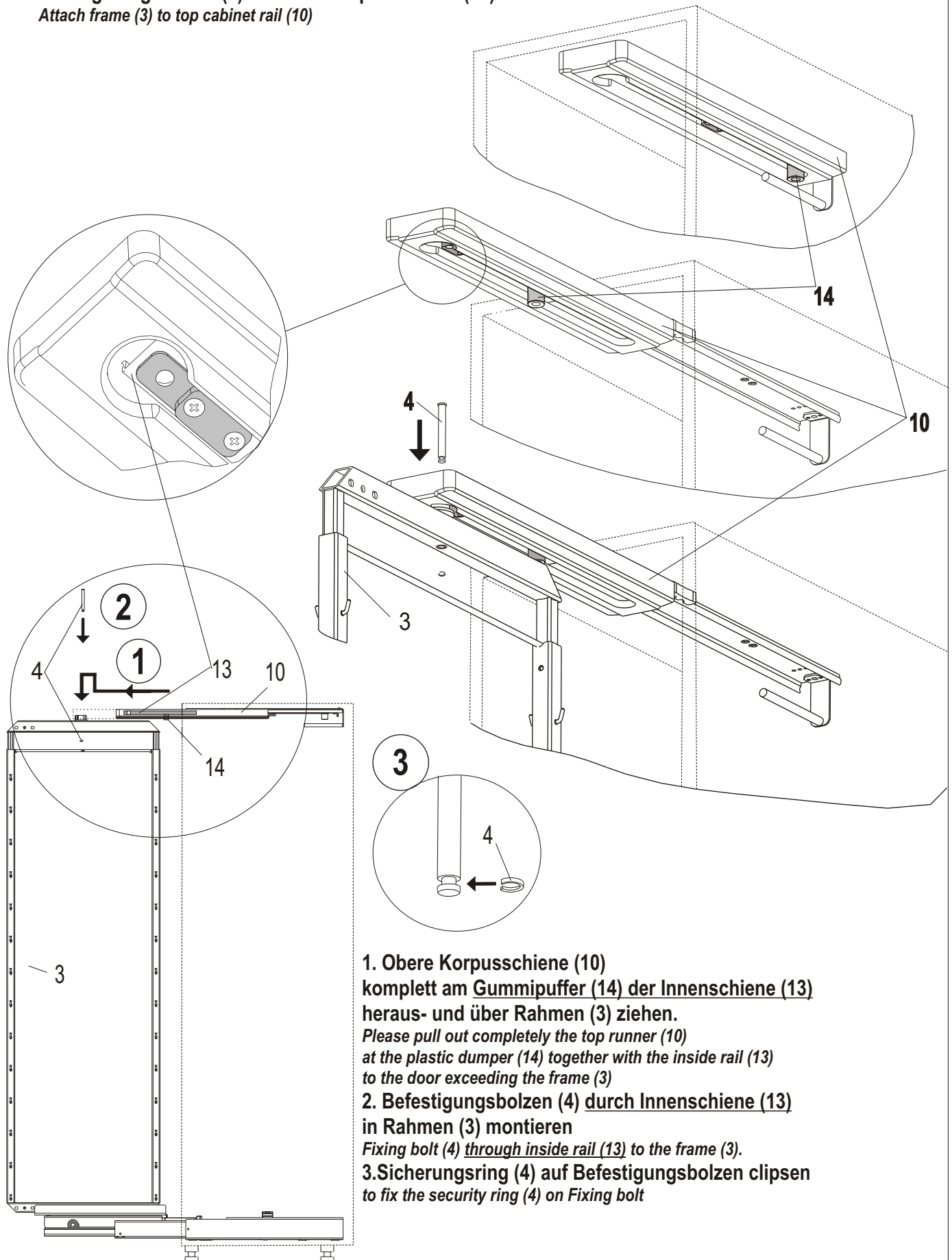

1. Obere Korpuschiene (10) komplett am Gummipuffer (14) der Innenschiene (13) heraus- und über Rahmen (3) ziehen.

Please pull out completely the top runner (10) at the plastic bumper (14) together with the inside rail (13) to the door exceeding the frame (3)

2. Befestigungsbolzen (4) durch Innenschiene (13) in Rahmen (3) montieren

Fixing bolt (4) through inside rail (13) to the frame (3).

3. Sicherungsring (4) auf Befestigungsbolzen clippen
to fix the security ring (4) on Fixing bolt

F. Montage der Frontschienen (1) und des Fronthalters (2). Attach front panel profile (1) and front panel connector (2)

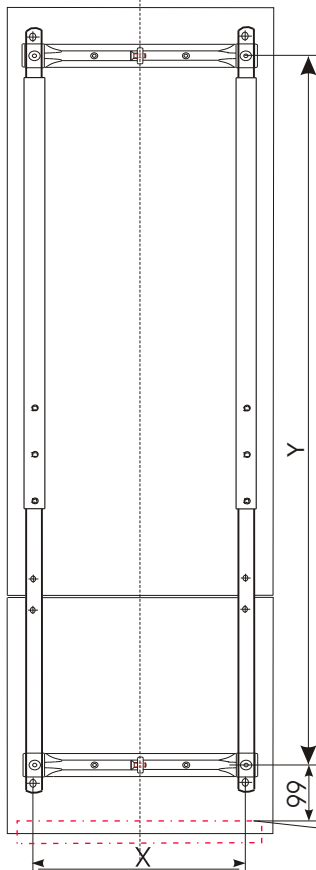

Schrankmaß	X
250	175
275	200
300	225
350	275
400	325
450	375
500	425
550	475
600	525

Y = lichte Schrankhöhe - 159mm

Y = inside cabinet height - 159 mm

99
Oberkante Unterboden
Top edge of bottom panel

G. Korpus ausrichten. Level cabinet

Hochschrank gegen kippen sichern
Fix cabinet to make sure it cannot tilt forward

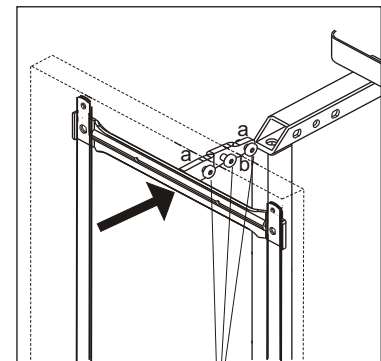
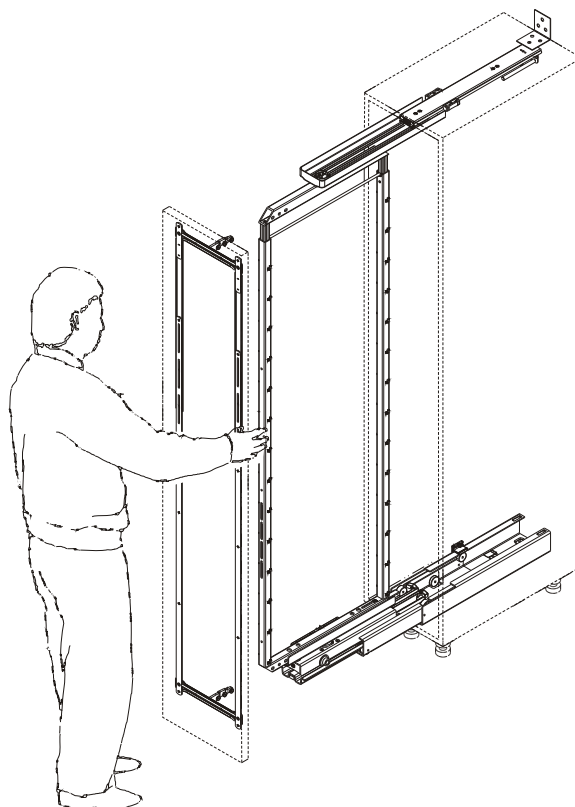
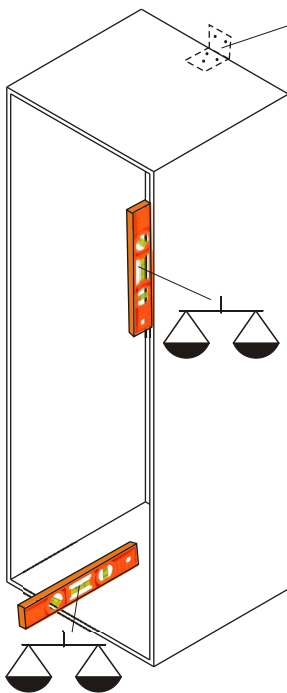

vormontierte Verstellerschraube (a)
und Befestigungsschrauben (b)
benutzen!

Use premounted adjusting screw (a)
and fixing screws (b)

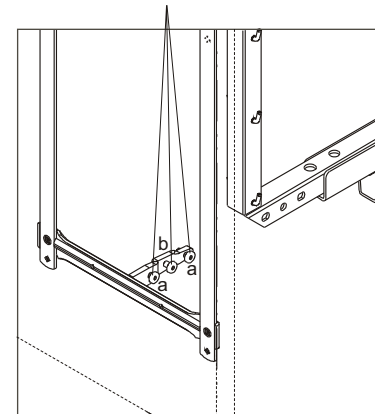

H. Justierung der Front *Align front panel*



Achtung:
Befestigungsschrauben
vor dem Verstellen lösen

CAUTION

*Loosen fixing screws
before making
any adjustments*

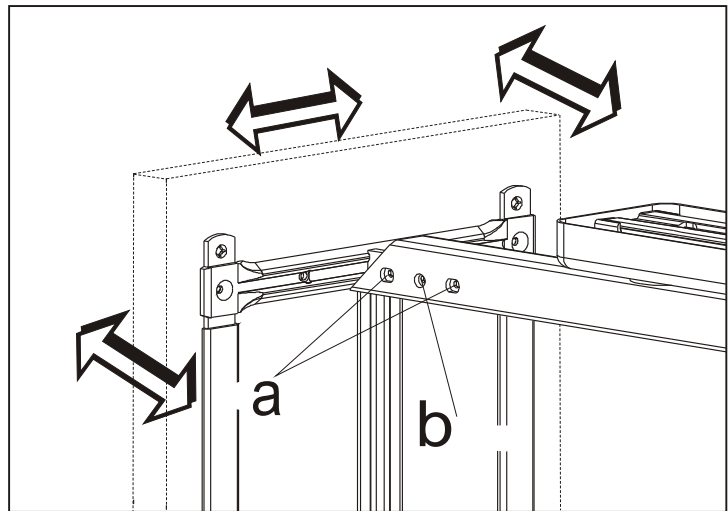

a - verstellen
adjusting

b - fixieren
fixing

I. Höhenverstellung und Einstellung der Frontneigung *Adjust front panel high and tilt angle*

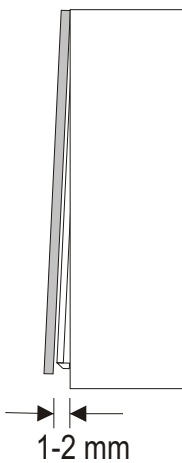

Achtung:
Vorspannung
beachten

Beim Einbau muss die
Front oben früher als
unten anschlagen

CAUTION

Front panel bias
*The top of the front panel
must close against
the cabinet before the bottom*

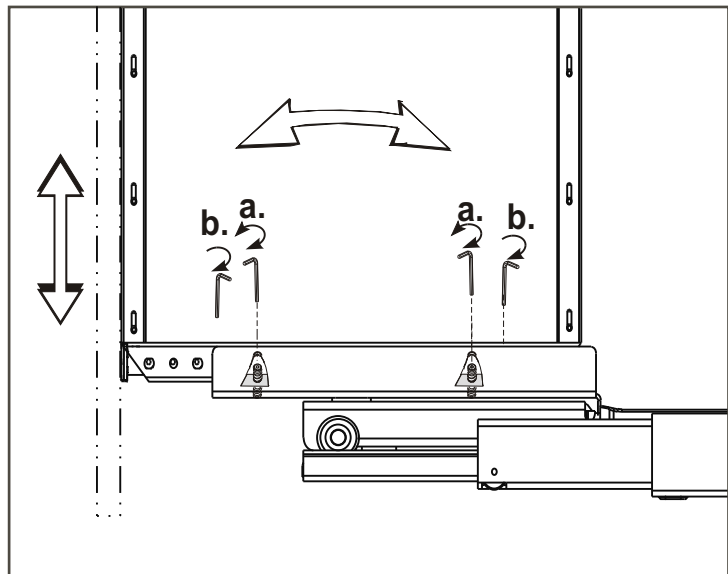

J. Der Einstellschlüssel (5) wird im hinteren Bereich des Tragrahmens (3) platziert *Position adjusting key (5) at rear of Frame (3).*

